

ANEXO - I
RELATÓRIO
FOTOGRAFICO

SETOR 01 - GABINETES

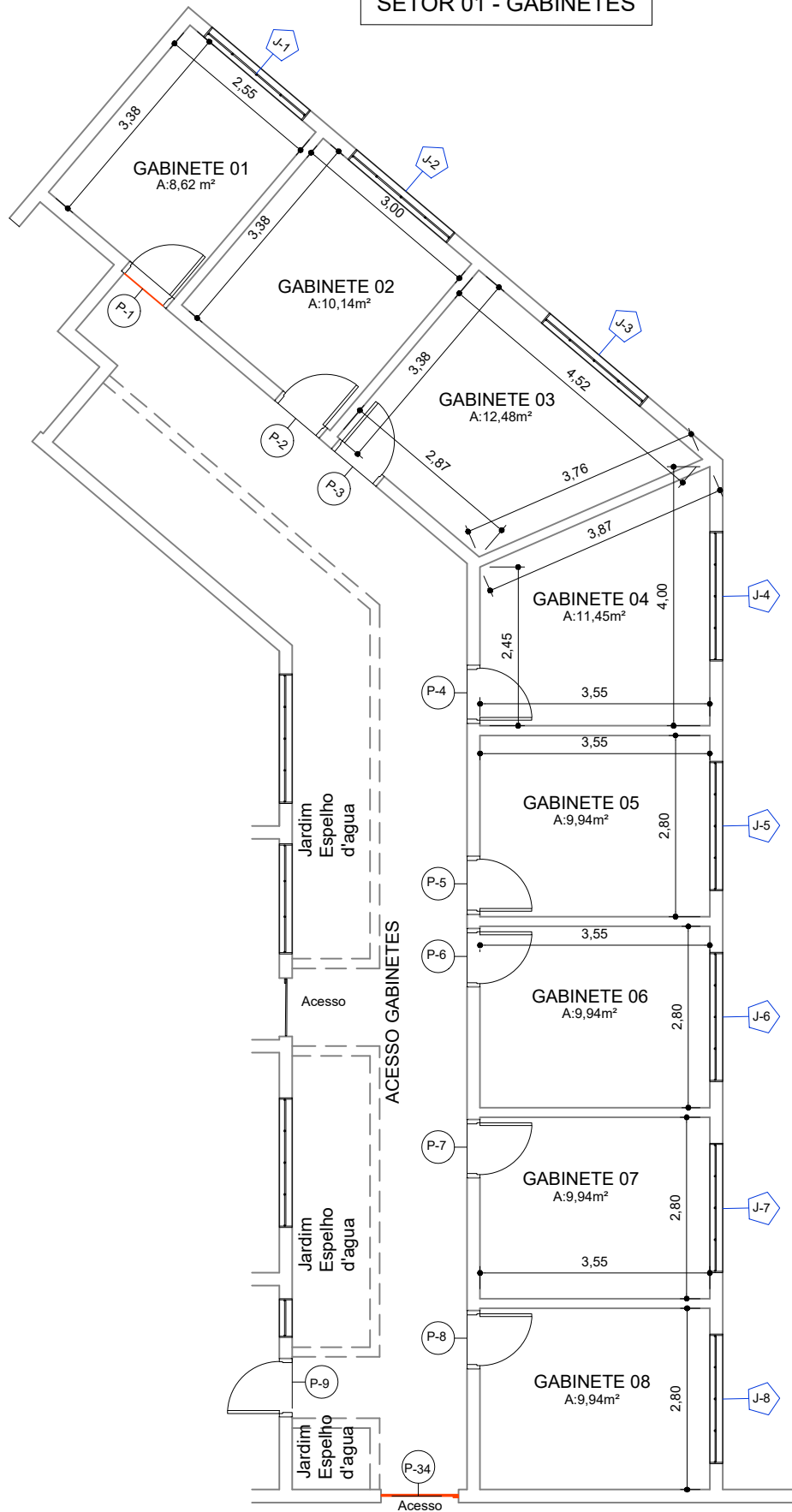

SETOR 01 - GABINETES

TABELAS DE ESQUADRIA

AMBIENTE	ID	AMBIENTE (M²)
GABINETE 01	P-1	8,62
GABINETE 02	P-2	10,14
GABINETE 03	P-3	12,48
GABINETE 04	P-4	11,45
GABINETE 05	P-5	9,94
GABINETE 06	P-6	9,94
GABINETE 07	P-7	9,94
GABINETE 08	P-8	9,94
CORREDOR	P-34	

TABELAS DE ESQUADRIA

AMBIENTE	ID
GABINETE 01	J-1
GABINETE 02	J-2
GABINETE 03	J-3
GABINETE 04	J-4
GABINETE 05	J-5
GABINETE 06	J-6
GABINETE 07	J-7
GABINETE 08	J-8

SETOR 01 - GABINETES



Foto 01 - Gabinete



Foto 02 - Gabinete



Foto 03 - Gabinete



Foto 04 - Gabinete



Foto 05 - Acesso Gabinetes



Foto 06 - Acesso Gabinetes



Foto 07 - Gabinetes



Foto 08 - Gabinetes

SETOR 02 - GABINETES

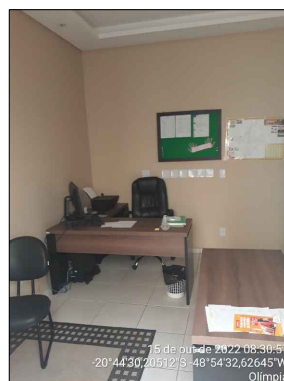
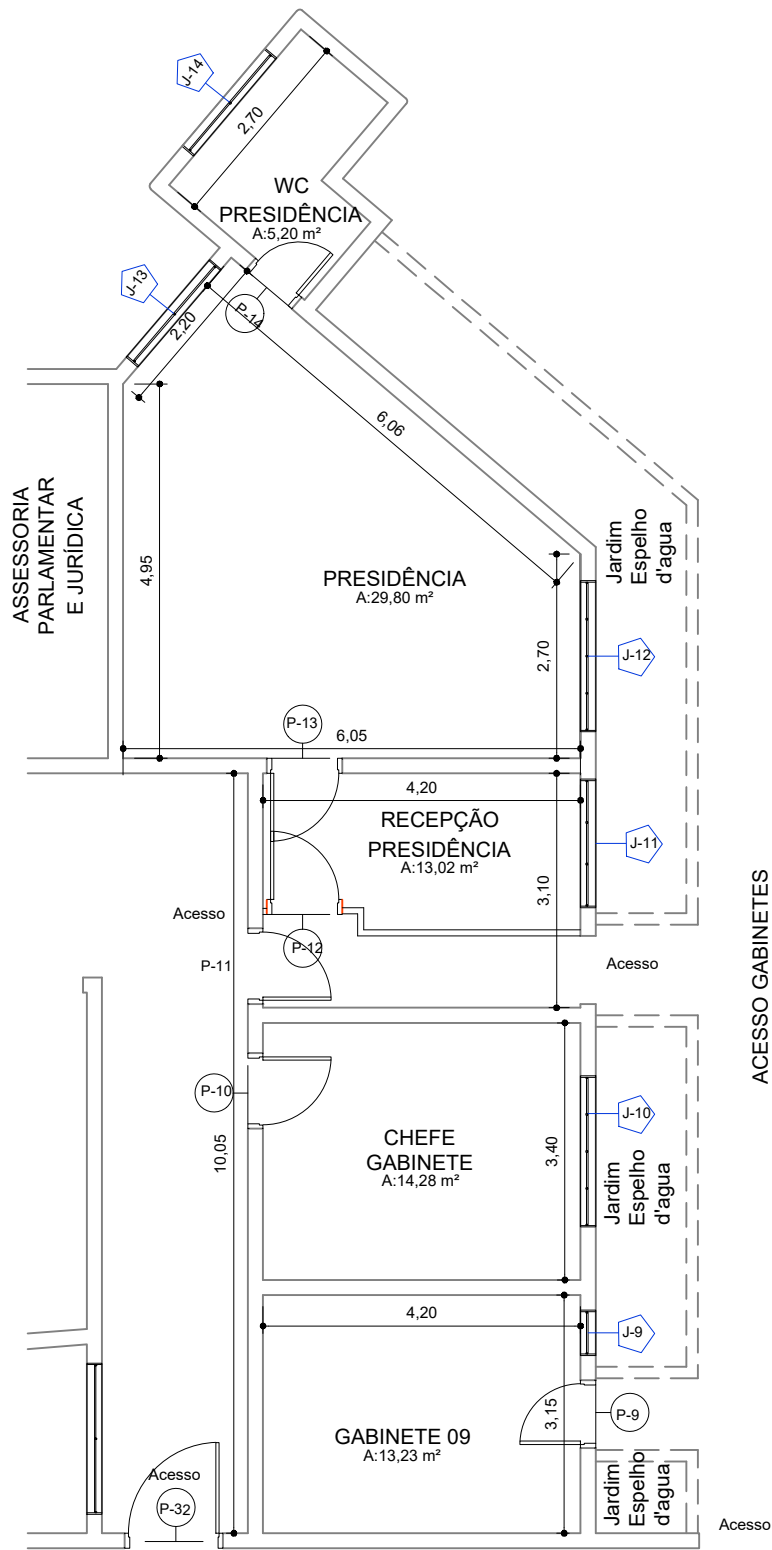

SETOR 02 - GABINETES

TABELAS DE ESQUADRIA

AMBIENTE	ID	AMBIENTE (M²)
GABINETE 09	P-9	13,23
CHEFE GABINETE	P-10	14,28
RECEPÇÃO PRESIDENCIA	P-11	13,02
	P-12	
PRESIDENCIA	P-13	29,80
WC PRESIDENCIA	P-14	5,20

TABELAS DE ESQUADRIA

AMBIENTE	ID
GABINETE 09	J-9
CHEFE GABINETE	J-10
RECEPÇÃO PRESIDENCIA	J-11
PRESIDENCIA	J-12
	J-13
WC PRESIDENCIA	J-14

SETOR 02 - GABINETES



Foto 09 - Sala do Presidente da Câmara



Foto 10 - Sala do Presidente da Câmara



Foto 11 - Sala do Presidente da Câmara

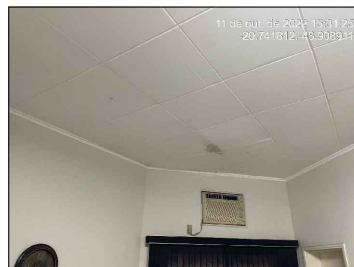

Foto 12 - Sala do Presidente da Câmara



Foto 13 - Banheiro Sala do Presidente da Câmara



Foto 14 - Banheiro Sala do Presidente da Câmara



Foto 15 - Chefe de Gabinete



Foto 16 - Chefe de Gabinete

SETOR 02 - GABINETES



Foto 17 - Chefe de Gabinete



Foto 18 - Chefe de Gabinete

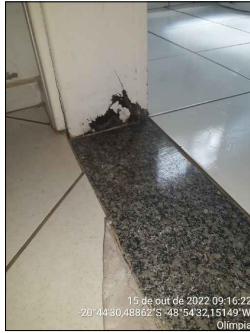

Foto 19 - Chefe de Gabinete



Foto 20 - Chefe de Gabinete

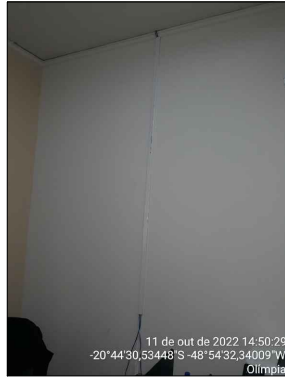

Foto 21 - Chefe de Gabinete

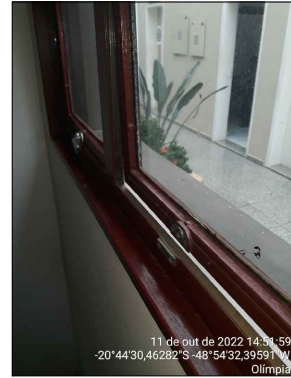

Foto 22 - RECEPÇÃO PRESIDENCIA



Foto 23 - RECEPÇÃO PRESIDENCIA



Foto 24 - RECEPÇÃO PRESIDENCIA

SETOR 03 - SALAS ADMINISTRATIVAS

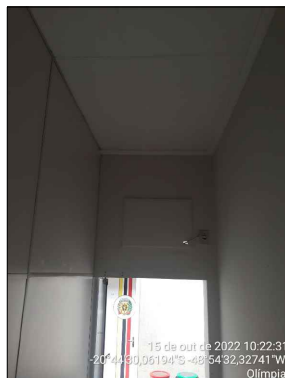

SETOR 03 - SALAS ADMINISTRATIVAS
(Área de Intervenção)

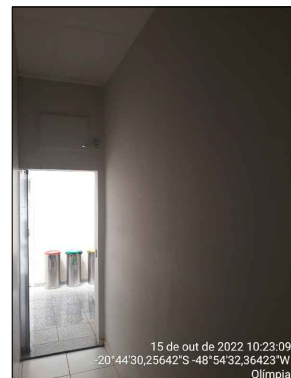
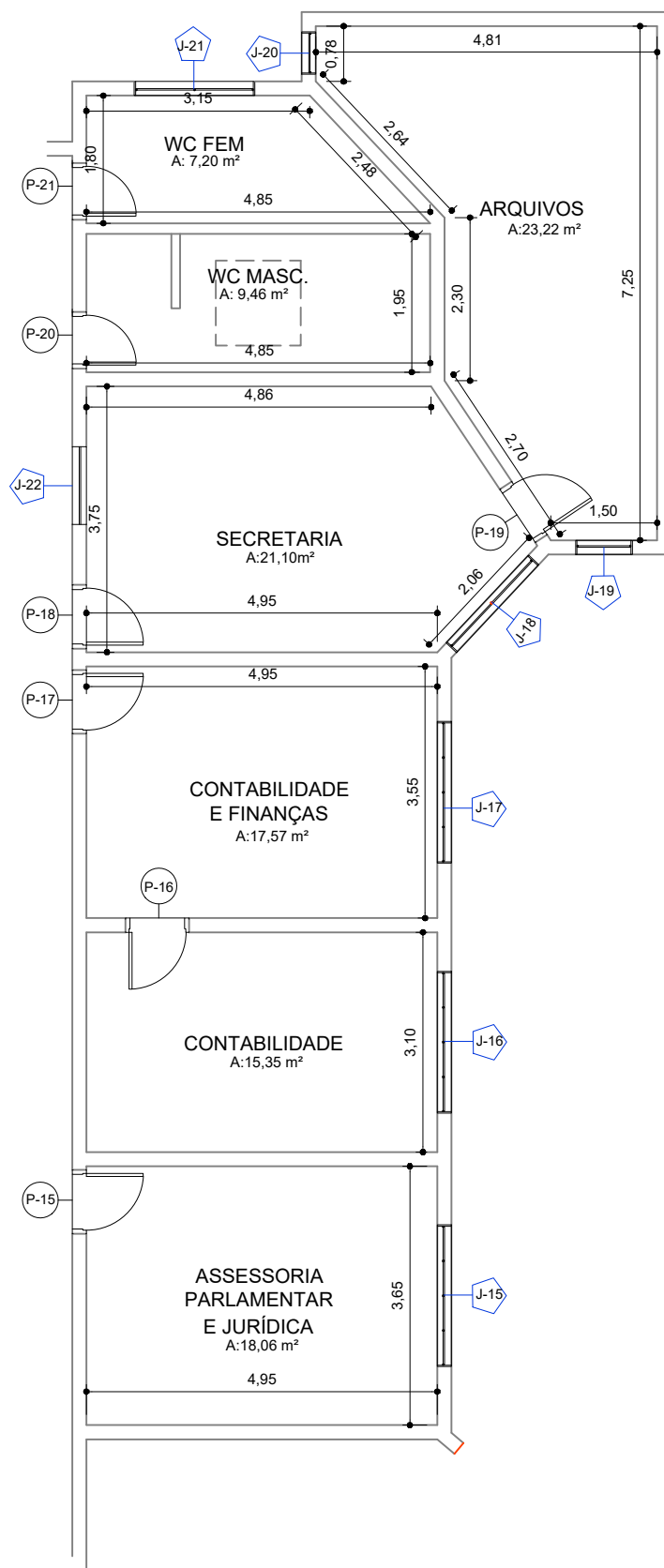
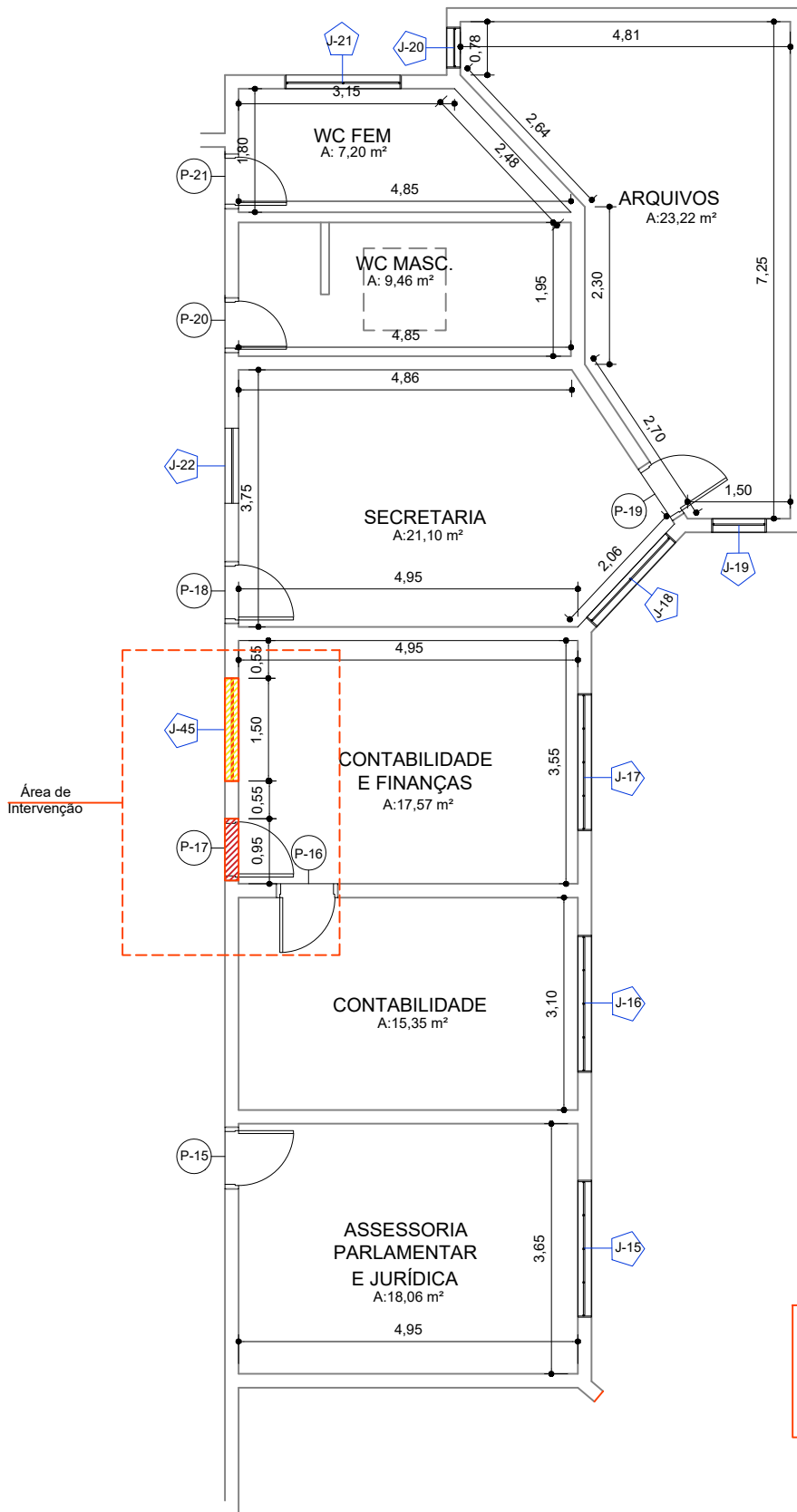

SETOR 03 - SALAS ADMINISTRATIVAS

TABELAS DE ESQUADRIA		
AMBIENTE	ID	AMBIENTE (M ²)
ASSESSORIA PARLAMENTAR E JURIDICA	P-15	18,06
CONTABILIDADE	P-16	15,35
CONTABILIDADE E FINANÇAS	P-17	17,57
SECRETARIA	P-18	21,10
ARQUIVOS	P-19	23,22
WC MASCULINO	P-20	9,46
WC FEMININO	P-21	7,20

TABELAS DE ESQUADRIA	
AMBIENTE	ID
ASSESSORIA PARLAMENTAR E JURIDICA	J-15
CONTABILIDADE	J-16
CONTABILIDADE E FINANÇAS	J-17
	J-45
SECRETARIA	J-18
	J-22
ARQUIVOS	J-19
	J-20
WC MASCULINO	ABERTURA ZENITAL
WC FEMININO	J-21

SETOR 03 - SALAS ADMINISTRATIVAS



Foto 25 - W.C. FEMININO



Foto 26 - W.C. MASCULINO



Foto 27 - W.C. FEMININO



Foto 28 - W.C. FEMININO



Foto 29 - JURIDICO



Foto 30 - JURIDICO



Foto 31 - JURIDICO



Foto 32 - SECRETARIA

SETOR 03 - SALAS ADMINISTRATIVAS



Foto 33 - JURIDICO



Foto 34 - CONTABILIDADE



Foto 35 - CONTABILIDADE



Foto 36 - CONTABILIDADE

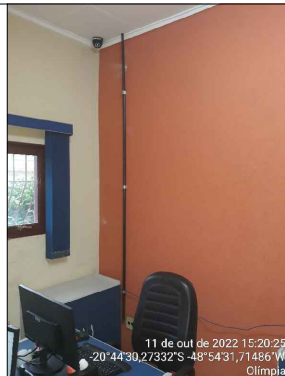

Foto 37 - CONTABILIDADE



Foto 38 - CONTABILIDADE



Foto 39 - CONTABILIDADE



Foto 40 - CONTABILIDADE

SETOR 04 - SALAS ADMINISTRATIVAS

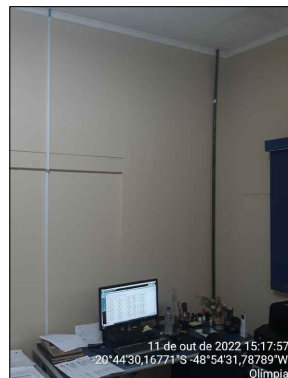

SETOR 04 - SALAS ADMINISTRATIVAS

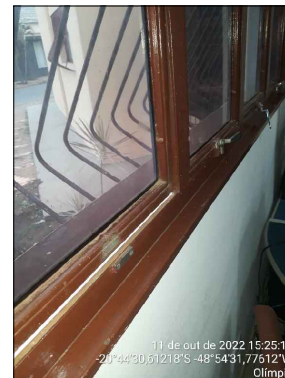
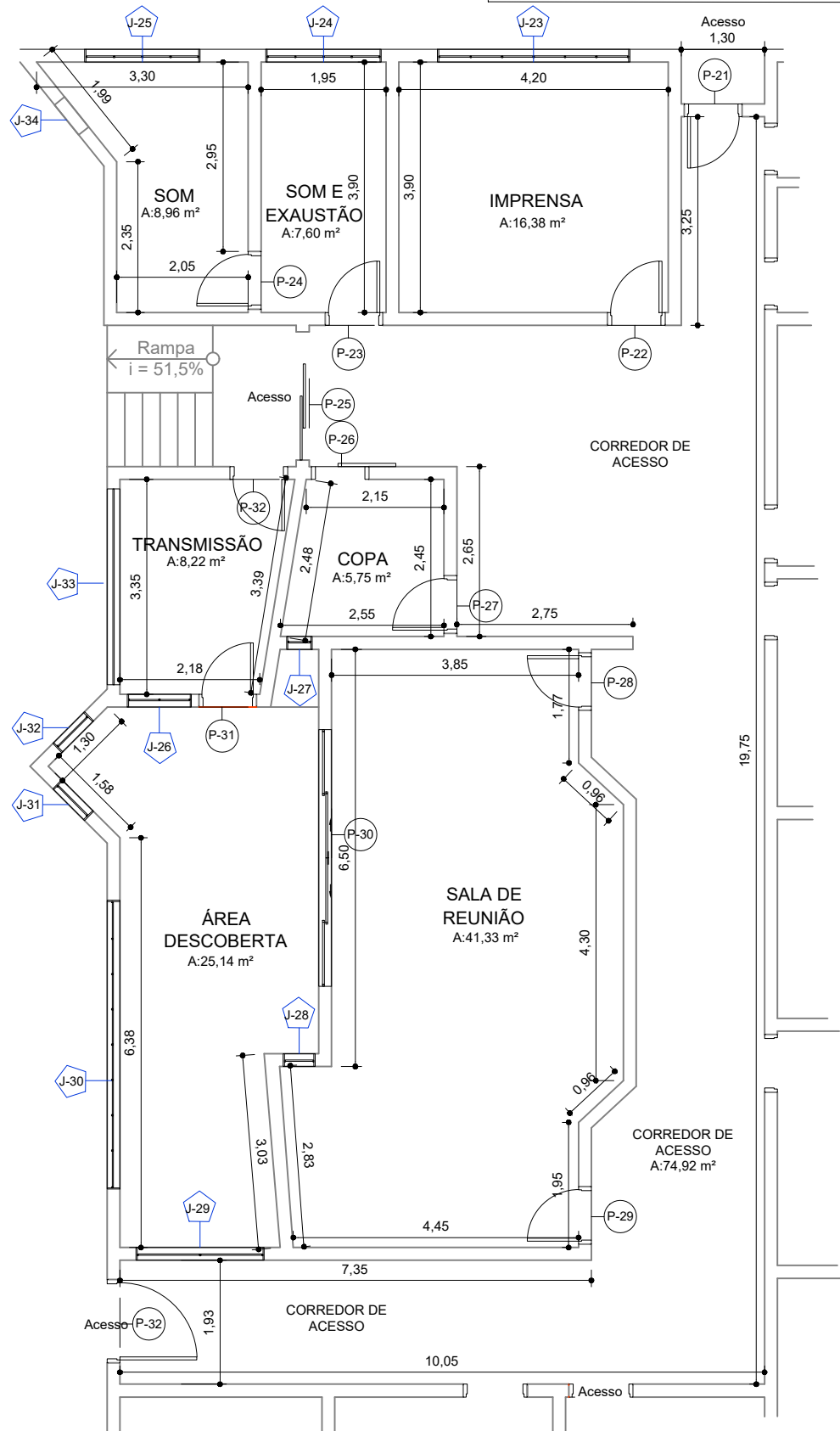
TABELAS DE ESQUADRIA		
AMBIENTE	ID	AMBIENTE (M ²)
IMPrensa	P-22	16,38
SOM E EXAUSTÃO	P-23	7,60
SOM	P-24	8,96
TRANSMISSÃO	P-32	8,22
	P-31	
COPA	P-26	5,75
	P-27	
SALA DE REUNIÃO	P-28	41,33
	P-29	
	P-30	
CORREDOR DE ACESSO	P-25	74,92
	P-32	
	P-21	

TABELAS DE ESQUADRIA	
AMBIENTE	ID
IMPrensa	J-23
SOM E EXAUSTÃO	J-24
SOM	J-25
	J-34
TRANSMISSÃO	J-26
	J-33
COPA	J-27
SALA DE REUNIÃO	J-28
CORREDOR DE ACESSO	J-29

SETOR 04 - SALAS ADMINISTRATIVAS



Foto 41 - CORREDOR DE ACESSO



Foto 42 - ACESSO SALA DE REUNIÃO



Foto 43 - CORREDOR DE ACESSO



Foto 44 - SALA DE REUNIÃO



Foto 45 - SALA DE REUNIÃO



Foto 46 - ACESSO SALA DE REUNIÃO



Foto 47 - SALA DE REUNIÃO



Foto 48 - ÁREA DESCOBERTA (J-27)

SETOR 04 - SALAS ADMINISTRATIVAS

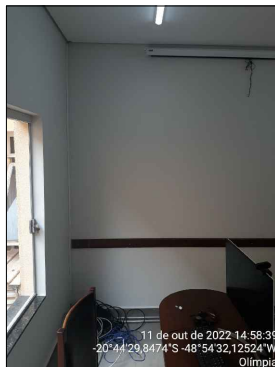

Foto 49 - ÁREA DESCOBERTA (J-32)



Foto 50 - ÁREA DESCOBERTA (P-31)



Foto 51 - ÁREA DESCOBERTA (J-26)



Foto 52 - SALA TRANSMISSÃO



Foto 53 - CORREDOR DE ACESSO



Foto 54 - CORREDOR DE ACESSO



Foto 55 - CORREDOR DE ACESSO

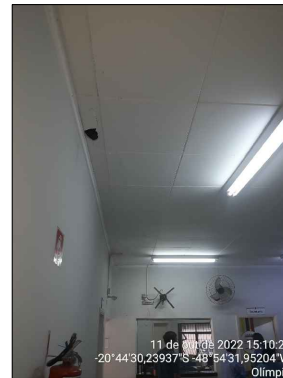

Foto 56 - CORREDOR DE ACESSO

SETOR 04 - SALAS ADMINISTRATIVAS



Foto 57 - COPA



Foto 58 - IMPRESSA



Foto 59 - SOM E EXAUSTÃO



Foto 60 - SOM E EXAUSTÃO



Foto 61 - IMPRESSA



Foto 62 - IMPRESSA



Foto 63 - IMPRESSA



Foto 64 - CORREDOR DE ACESSO (P-21)

SETOR 05 - SALAS PLENARIO

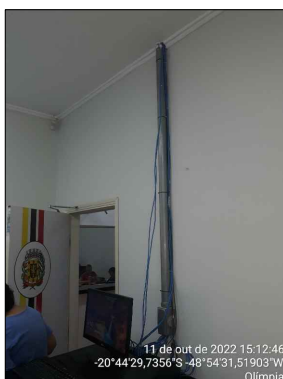
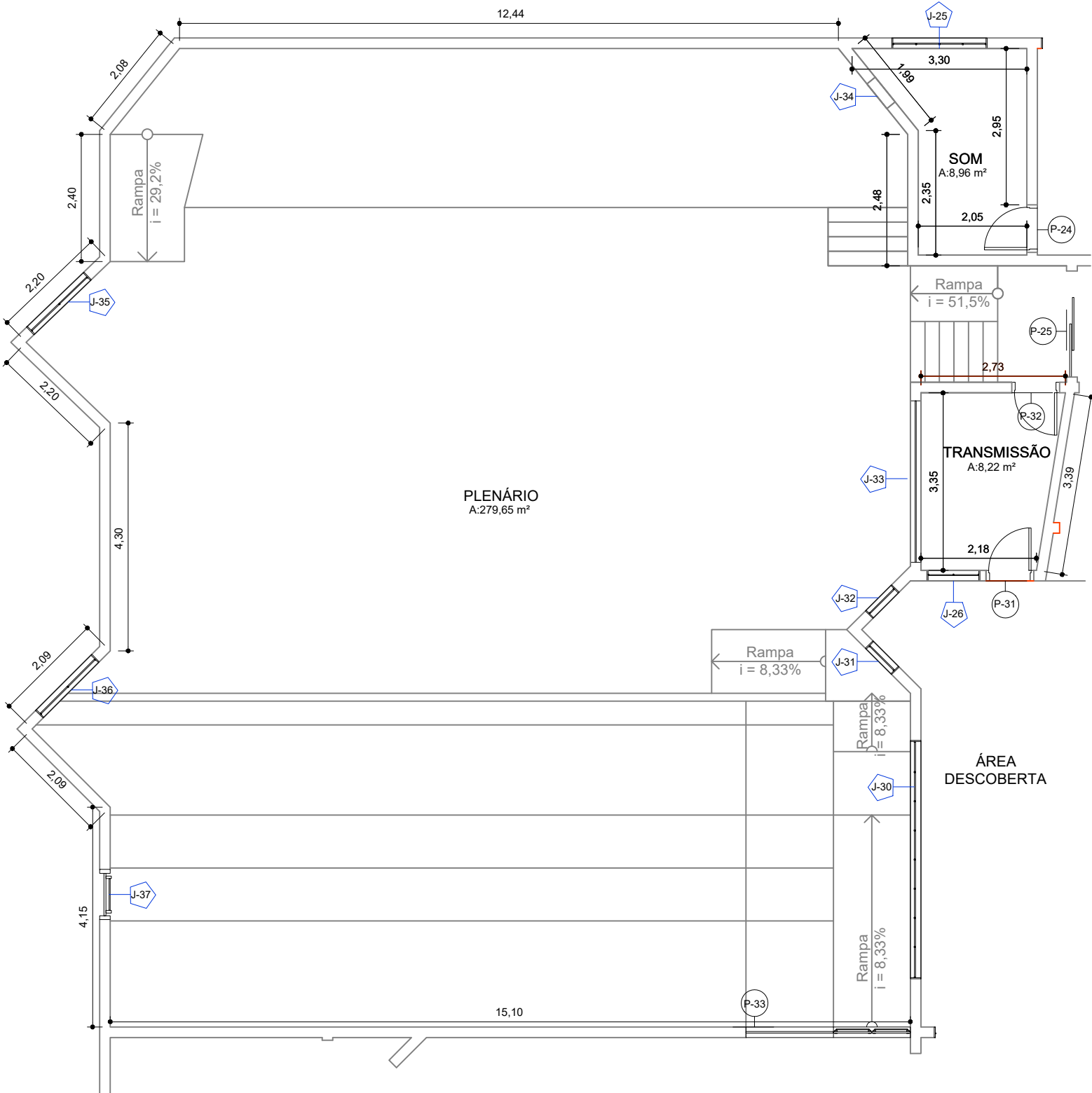

SETOR 05 - SALAS PLENARIO

TABELAS DE ESQUADRIA		
AMBIENTE	ID	AMBIENTE (M²)
PLENÁRIO	P-33	279,65

TABELAS DE ESQUADRIA	
AMBIENTE	ID
PLENÁRIO	J-30
	J-31
	J-32
	J-35
	J-36
	J-37
TRANSMISSÃO	J-33
SOM	J-34

SETOR 05 - SALAS PLENARIO



Foto 65 - PLENÁRIO



Foto 66 - PLENÁRIO



Foto 67 - PLENÁRIO



Foto 68 - PLENÁRIO



Foto 69 - PLENÁRIO

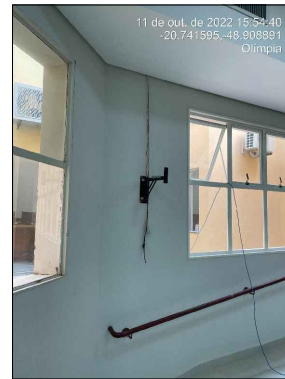

Foto 70 - PLENÁRIO



Foto 71 - TRANSMISSÃO



Foto 72 - PLENÁRIO

SETOR 06 - SALAS ADMINISTRATIVAS

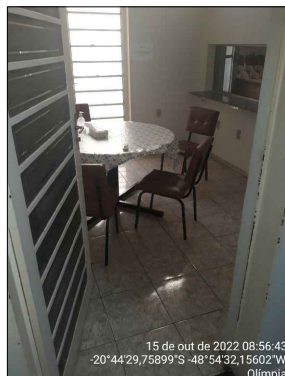

SETOR 06 - RECEPÇÃO

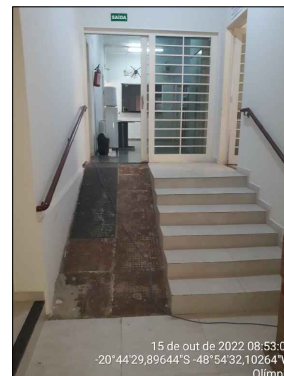
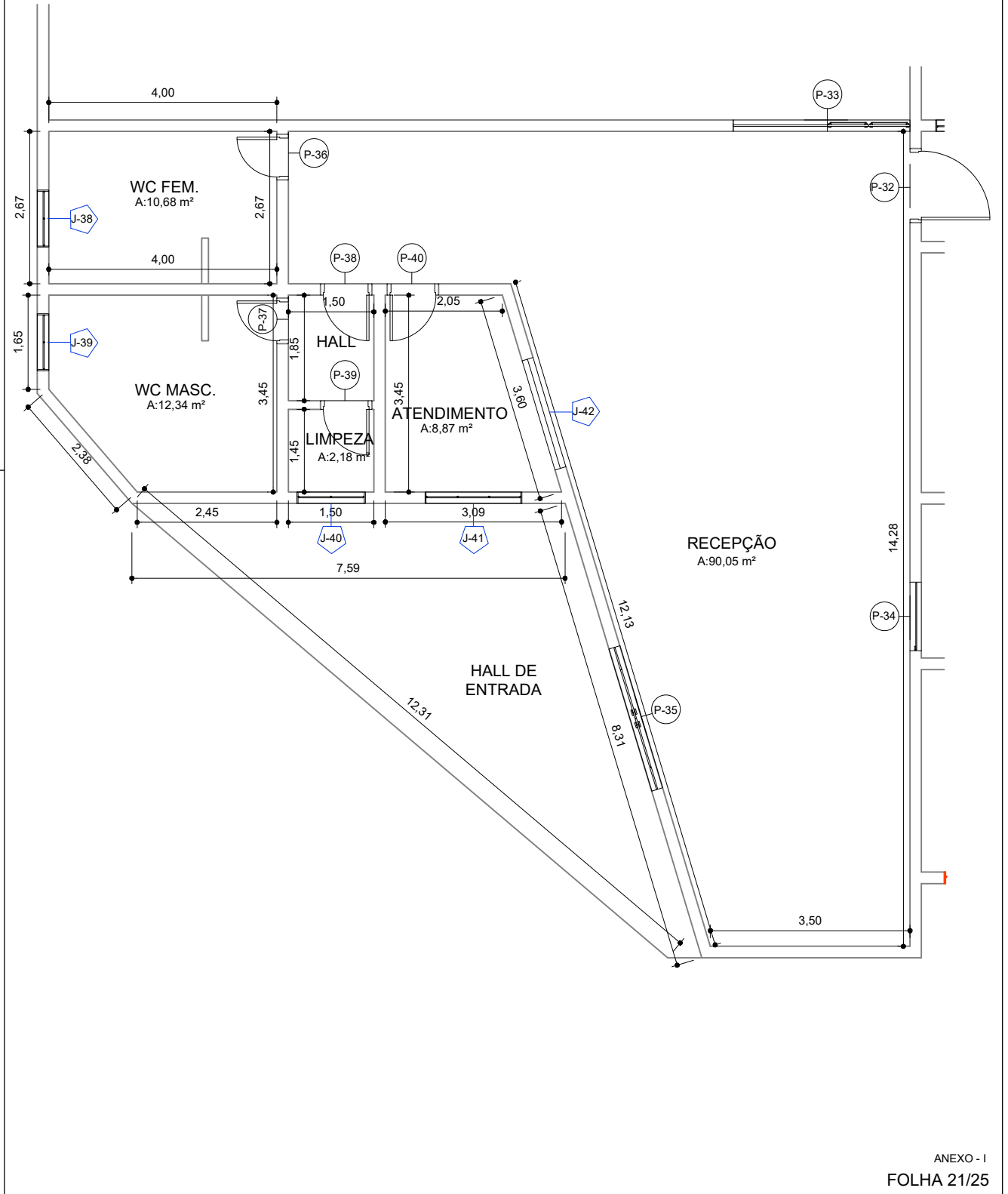
TABELAS DE ESQUADRIA		
AMBIENTE	ID	AMBIENTE (M²)
RECEPÇÃO	P-32	90,05
	P-33	
	P-34	
	P-35	
ATENDIMENTO	P-40	8,87
LIMPEZA	P-39	2,18
HALL	P-38	2,78
WC MASCULINO	P-37	12,34
WC FEMININO	P-36	10,68

TABELAS DE ESQUADRIA	
AMBIENTE	ID
RECEPÇÃO	J-42
ATENDIMENTO	J-41
LIMPEZA	J-40
HALL	-
WC MASCULINO	J-39
WC FEMININO	J-38

SETOR 06 - RECEPÇÃO



Foto 73 - RECEPÇÃO



Foto 74 - W.C. BANHEIRO



Foto 75 - W.C. BANHEIRO



Foto 76 - LIMPEZA



Foto 77 - ATENDIMENTO

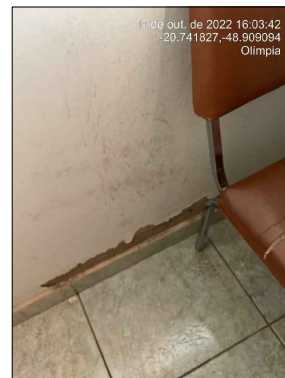

Foto 78 - ATENDIMENTO

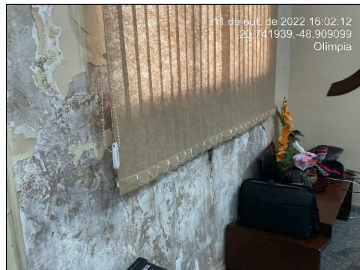

Foto 79 - ATENDIMENTO

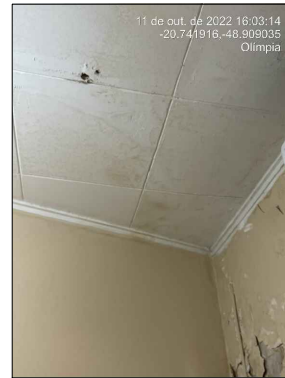

Foto 80 - ATENDIMENTO

SETOR 06 - RECEPÇÃO



Foto 81 - RECEPÇÃO



Foto 82 - BANHEIRO RECEPÇÃO

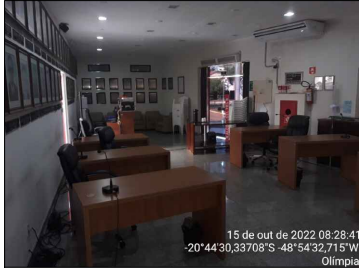

Foto 83 - HALL DE LIMPEZA



Foto 84 - BANHEIRO RECEPÇÃO

SETOR 06 - FACHADAS



Foto 85 - Fundo Camara Municipal



Foto 86 - Janela Banheiro Fundo

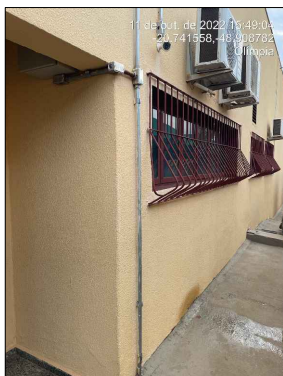

Foto 87 - Fachada



Foto 88 - Hall de Entrada



Foto 89 - Fachada



Foto 90 - Hall de Entrada

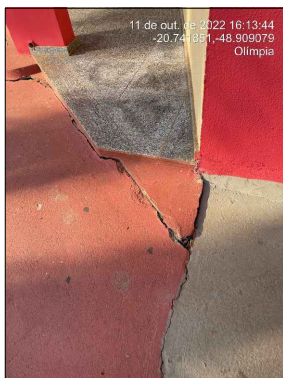

Foto 91 - Fachada



Foto 92 - Hall de Entrada